

BB2VHB

Čelust'ové lyžice na repu

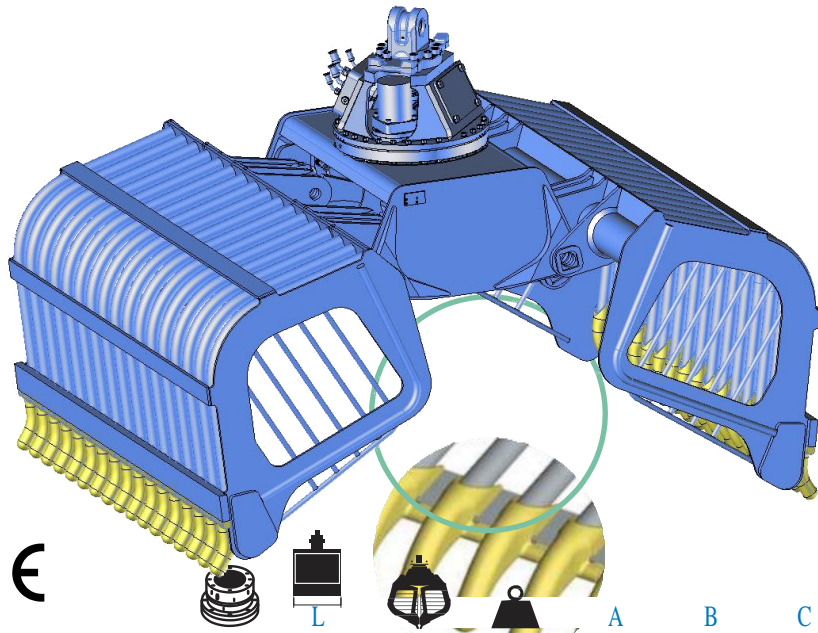

Variant ulít :



- 1 Vnútrotný kardanový plášť.
- 2 Rotácia 360° vsadená do konštrukcie.
- 3 Konštrukcia vyrobená z HLE ocele pre lepšie rozloženie nákladu. 2 vodorovné valce s koncovým tlmičom chránené vo vnútri rámu. Podporná ojníčka včlenená do rámu.
- 4 Ulity poskytujú veľký objem na naplnenie. Osobitá kinematika zabraňuje poškodeniu repy.
- 5 Možnosť prispôsobenia ulít na manipuláciu s materiálom.
- 6 Vzájomne vymeniteľné profilované zuby na redukciu chýb pôdy.

CE



A

B

C

D



	t	mm	lt	kg	mm	mm	mm	mm	bar	l/mn	bar	l/mn
BB2VHB1401600R1C	9	1400	1600	1360	1805	1505	1610	2460	350	50/120	150/200	13/18
BB2VHB1501750R1C	9	1500	1750	1400	1805	1505	1610	2460	350	50/120	150/200	13/18
BB2VHB1802000R1C	15	1800	2000	1560	1805	1505	1610	2460	350	50/120	150/250	18/27
BB2VHB2002300R1C	15	2000	2300	1640	1805	1505	1610	2460	350	50/120	150/250	18/27
BB2VHB2202600R1C	15	2200	2600	1720	1805	1505	1610	2460	350	50/120	150/250	18/27
BB2VHB2352750R1C	15	2350	2750	1760	1805	1505	1610	2460	350	50/120	150/250	18/27

kg : Hmotnosť bez kardanu

BB2VHB 1400 - 1500 - 1800 - 2000 - 2200 - 2350

